

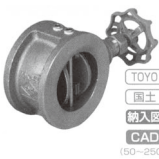







ウイングチェックバルブ

分類	ウイングチェックバルブ(衝撃吸収式)														
	青銅			鋳鉄			ダクタイル鋳鉄			ステンレス					
クラス	10K						20K			10K			20K		
形状															
製品コード	01A3E07			03A3E31			02A3G19			04B3E16			04B3G06		
本体材料	CAC406			FC250			FCD-S			SCS13					
弁体材料	CAC406						SCS13								
製品記号	10-BNW			10-FNW			20-DNW			10-UNW			20-UNW		
呼び径	L	H	価格	L	H	価格	L	H	価格	L	H	価格	L	H	価格
40A (1 1/2B)	54	132	76,100	54	128	43,600	54	128	55,300	54	118	114,000	54	118	○
50 (2)	56	139	78,900	56	143	44,300	56	133	56,900	60	126	116,000	60	126	193,000
65 (2 1/2)	56	146	102,000	56	150	48,800	60	150	60,400	67	134	149,000	67	134	218,000
80 (3)	59	152	118,000	59	156	56,500	67	156	75,600	73	138	165,000	73	138	251,000
100 (4)	66	165	157,000	66	169	71,800	68	169	91,300	73	151	209,000	73	151	367,000
125 (5)	72	183	204,000	72	183	93,800	83	183	139,000	86	174	310,000	86	174	535,000
150 (6)	78	208	277,000	78	216	126,000	95	216	182,000	98	188	396,000	98	188	646,000
200 (8)	96	237	412,000	96	243	187,000	127	243	270,000	127	215	547,000	127	215	823,000
250 (10)	109	289	613,000	109	290	321,000	140	290	426,000	146	254	952,000	146	254	1,425,000
300 (12)	145	316	896,000	145	315	456,000	181	315	549,000	181	282	1,390,000	181	282	2,008,000
350 (14)				184	330	795,000	184	330	○						
400 (16)				191	355	1,247,000	191	355	○						
450 (18)				204	388	○	204	388	○						

フランジ形ボールバルブ

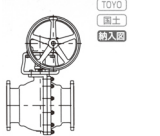
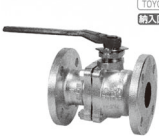
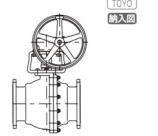
分類	鋳鉄						ダクタイル鋳鉄					
	10K						10K					
形状												
製品コード	03K1E13			03K1E05			02K1E19			02K1E03		
本体材料	ねずみ鋳鉄FC200						ダクタイルFCD-S					
ボール材料	ステンレス SUS304 or SCS13A						ステンレス SUS304 or SCS13A					
シート材料	PTFE						変性PTFE					
ボア径	フルボア						フルボア					
製品記号	10-FBF-N-L			10-FBF-N-G			10-DBF-N-L			10-DBF-N-G		
呼び径	L	H	価格	L	H	価格	L	H	価格	L	H	価格
15A (1/2B)	110	102	13,400				108	106	19,000			
20 (3/4)	120	105	15,100				117	109	23,300			
25 (1)	130	124	20,400				127	130	27,300			
32 (1 1/4)	140	130	27,700				140	135	○			
40 (1 1/2)	165	115	33,300				165	115	45,700			
50 (2)	180	120	40,300				178	120	55,400			
65 (2 1/2)	190	155	66,500				190	153	78,000			
80 (3)	200	165	85,100				203	162	99,300			
100 (4)	230	200	124,000				229	199	142,000			
125 (5)	300	220	234,000	300	467	○	356	219	299,000	356	467	○
150 (6)	340	295	323,000	340	492	○	394	293	385,000	394	492	○
200 (8)	450	355	565,000	450	594	○	457	352	684,000	457	594	○

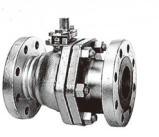
分類	鋳				鋼			
	10K/150				20K/300			
形状								
製品コード	05K2E17		05K2R58		05K2G16		05K2S66	
本体材料	SCPH2							
ボール材料	ステンレス SUS304 or SCS13A							
シート材料	変性PTFE							
ボア径	フルボア							
製品記号	K10-SBF-N-L		K150-SBF-N-L		K20-SBF-N-L		K300-SBF-N-L	
呼び径	L	H	価格	価格	L	H	価格	価格
15A (1/2B)	108	108	30,300	30,300	140	108	41,700	43,900
20 (3/4)	117	111	35,000	35,000	152	111	47,500	49,700
25 (1)	127	124	48,300	48,300	165	124	58,700	62,000
32 (1 1/4)								
40 (1 1/2)	165	134	64,000	64,000	190	134	83,100	88,700
50 (2)	178	143	82,000	82,000	216	143	108,000	115,000
65 (2 1/2)	190	179	121,000	121,000	241	179	180,000	190,000
80 (3)	203	189	148,000	156,000	283	189	220,000	227,000
100 (4)	229	224	201,000	206,000	305	224	300,000	314,000
125 (5)	356	240	416,000	435,000	381	240	489,000	
150 (6)	394	315	497,000	524,000	403	315	666,000	718,000
200 (8)	457	406	840,000	879,000	502	406	1,149,000	1,237,000

※○につきましては、弊社までお問い合わせ下さい。